

ALFA

NC MILLING MACHINE

FRESATRICE CN PER PORTE, TELAI E PANNELLI IN LEGNO
NC MILLING MACHINE FOR DOORS, FRAMES AND WOODEN PANELS
FRAISEUSE CN POUR PORTES, CADRES ET PANNEAUX EN BOIS
CENTRO DE MECANIZADO PARA PUERTAS, MARCO Y PANELES DE MADERA

centauro[®]



ALFA

NC MILLING MACHINE



Fresatrice a controllo numerico a 3 assi controllati e interpolati specifica per lavorazioni su porte, telai e pannelli quali alloggiamento di serrature, cerniere, pomelle, piastre, foratura per maniglia, asola della chiave, telai di finestre, persiane, componenti di scale e mobili in genere. Grazie alla possibilità di configurare un quarto asse controllato ed un gruppo di foratura e avvitatura, la macchina permette all'operatore di programmare e realizzare l'inserimento di cerniere anuba (con caricatore automatico) su porta e telaio.

Concepita con le più recenti soluzioni tecniche, la macchina è a gestione completamente elettronica con motori brushless, viti a ricircolo di sfere e guide lineari con pattini a ricircolo di sfere. Direttamente da controllo elettronico touch screen si realizzano o si possono importare (tramite porta USB) programmi di lavoro in modo semplice e intuitivo utilizzando macro pre installate per l'esecuzione di fresature accurate. Cambio di lavorazione estremamente veloce. Una procedura semplice e guidata permette la rapida taratura degli assi per garantire sempre lavorazioni di massima precisione. Ogni specifico utensile, con tutte le sue caratteristiche, viene memorizzato sul controllo elettronico, per essere impiegato nelle più svariate lavorazioni. Tutto questo è ottenuto su una macchina solida dalle dimensioni contenute.

NC milling machine with 3 controlled and interpolated axis specifically for doors, frames and panel processing such as housing locks, hinges, pommels, plates, drilling for handle, keyhole, window frames, shutters, components of stairs and furniture in general.

Thanks to the possibility to configure a fourth controlled axis more a drilling and screw device, the machine allows the operator to program and machining the insertion of anuba hinges (with authomatic loader) on door and frame. Developed with the latest technical solutions, the machine is fully electronically organized with brushless motors, ball recirculating screws and with ball recirculating linear guides . Directly from the Electronic Control "touch screen", the operator can realize or import (via USB port) work programs in a simple and intuitive way using pre-installed macros to perform accurate milling. The change of working process is extremely quick. A simple and guided procedure allows quick calibration of the axes to ensure maximum precision machining. Each specific tool, with all its features, is stored on electronic control, to be used in the most various processes. The machine is also very heavy and compact.

QUALITA' E MASSIMA FLESSIBILITA' NELLE SOLUZIONI PER FRESATURA E ANUBATURA

QUALITY AND MAX FLEXIBILITY IN MILLING AND ANUBA HINGES INSERTING SOLUTIONS

QUALITE' ET MAX FLEXIBILITE' EN SOLUTIONS POUR FRAISAGE ET FICHES ANUBA

CALIDAD Y GRANDE FLEXIBILIDAD EN LAS SOLUCIONES PARA FRESADO Y BISAGRAS ANUBA

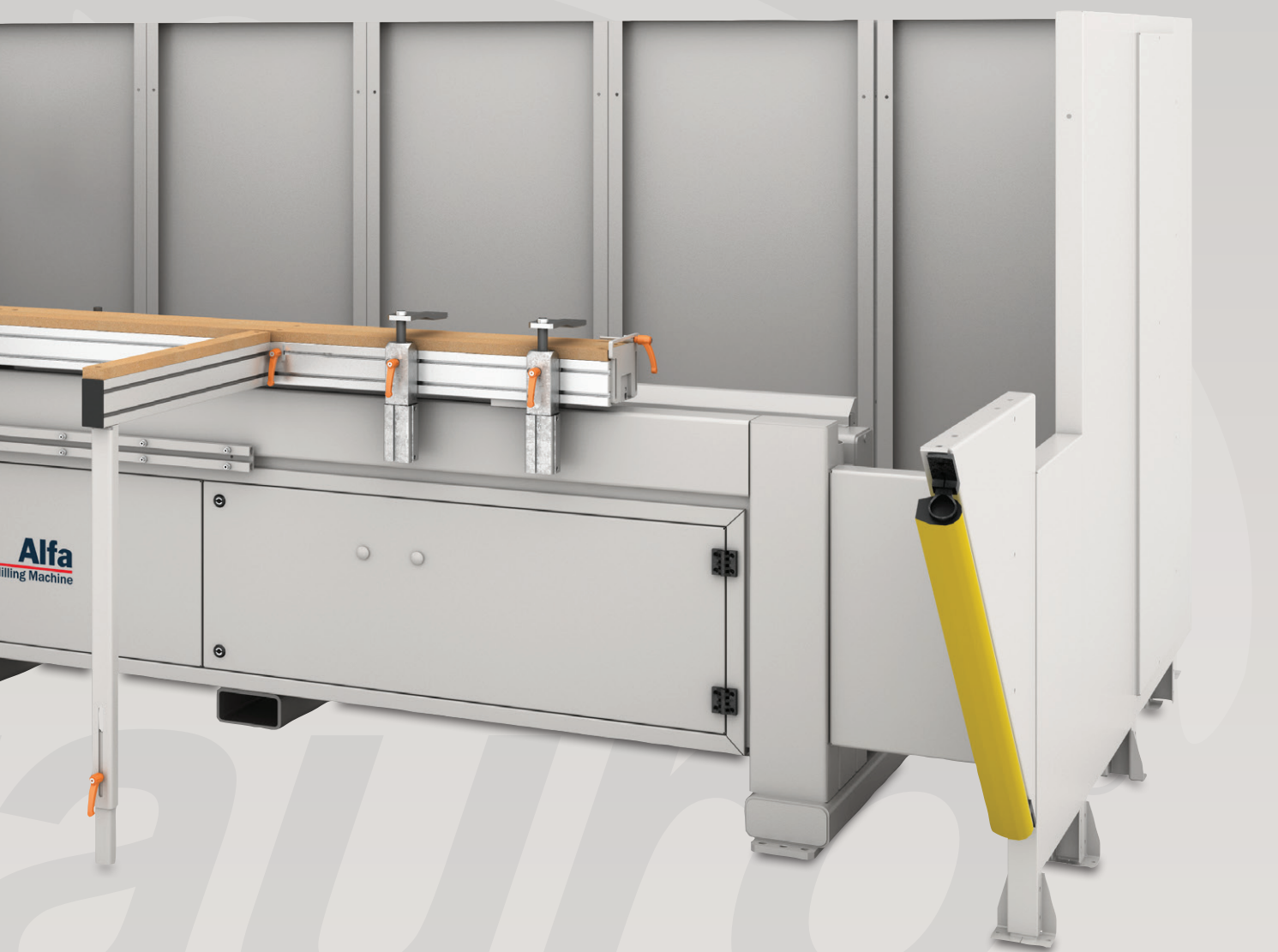

Fraiseuse à contrôle numérique avec 3 axes contrôlées et interpolées, spécifique pour travailler sur les portes, cadres et panneaux qui accueillent le logement des verrouilles, des charnières, des boutons, des plaques, le perçage pour poignée, emplacement de la clé, les cadres de fenêtres, volets, escaliers et composants de meubles en général. Grâce à la capacité de configurer un quatrième axe contrôlé, ainsi que d'un groupe de perçage et de vissage, la machine permet à l'opérateur de programmer et mettre en oeuvre l'insertion de charnières (Anuba avec chargeur automatique) sur la porte et le cadre. Conçue avec les dernières solutions techniques, la machine à management entièrement électronique avec des moteurs sans balais, des vis à billes et les guides linéaires à recirculation de billes. Directement à partir de la commande électronique de l'écran tactile on peut réaliser ou aussi importer (via le port USB) des programmes de travail très facilement et intuitivement, en employant de pré macros installées pour effectuer le fraisage précis. Le changement de processus de travail est extrêmement rapide. Une procédure simple et guidée permet l'étalonnage rapide des axes pour assurer en permanence l'usinage de précision maximale. Chaque outil spécifique, avec toutes ses caractéristiques, est stocké sur la commande électronique, à utiliser dans les opérations les plus variées. Tout ceci est réalisé sur une machine solide avec de petites dimensions.

Centro de mecanizado a control numerico con 3 ejes controlados y interpolado específico para trabajos en puertas, marcos y paneles cuales cerraduras de vivienda, bisagras, perillas, placas, agujeros de manijas, agujeros de llave, marcos de ventanas, persianas, escaleras y componentes de muebles en general. Gracias a la posibilidad de configurar un cuarto eje controlado más un grupo de perforación y atornillado, la máquina permite al operador de programar y realizar la inserción de bisagras anuba (con cargador automático) en la puerta y el marco. Desarrollado con las últimas soluciones técnicas, la máquina es totalmente a gestión electrónica con motores brushless, tornillos de bolas y guías lineales con recirculación de bolas. Directamente desde la pantalla táctil del control electrónico se realizan o se pueden importar (a través del USB) los programas de trabajo en forma fácil e intuitiva, utilizando plantillas pre-instaladas para realizar fresados de alta precisión. Cambio de procesamiento extremadamente rápido. Un procedimiento sencillo y guiado permite la rápida calibración de los ejes para asegurar un mecanizado de precisión. Cada herramienta, con todas sus características, se almacena en el control electrónico, para ser utilizado en variadas operaciones. Todo esto se consigue en una máquina sólida con dimensiones pequeñas.

ALFA NC MILLING MACHINE

QUALITÀ E MASSIMA FLESSIBILITÀ NELLE SOLUZIONI PER FRESATURA E ANUBATURA

QUALITY AND MAX FLEXIBILITY IN MILLING AND ANUBA HINGES INSERTING SOLUTIONS

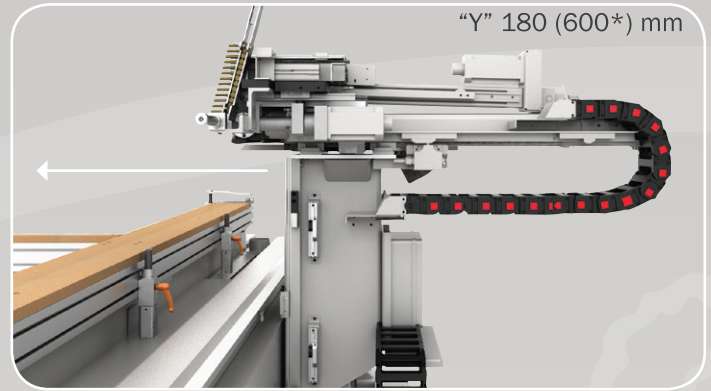
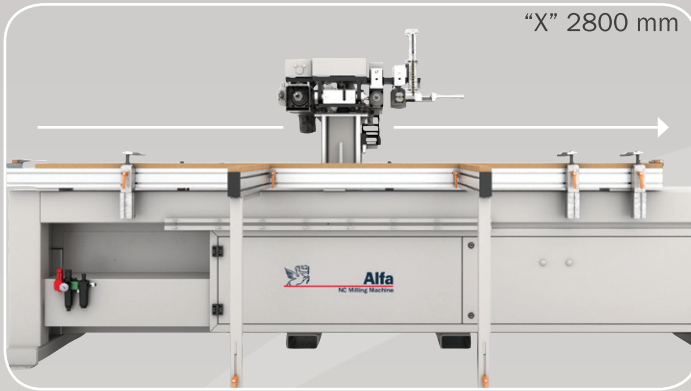

PROGRAMMAZIONE

PROGRAMMING

PROGRAMMATION

PROGRAMACIÓN

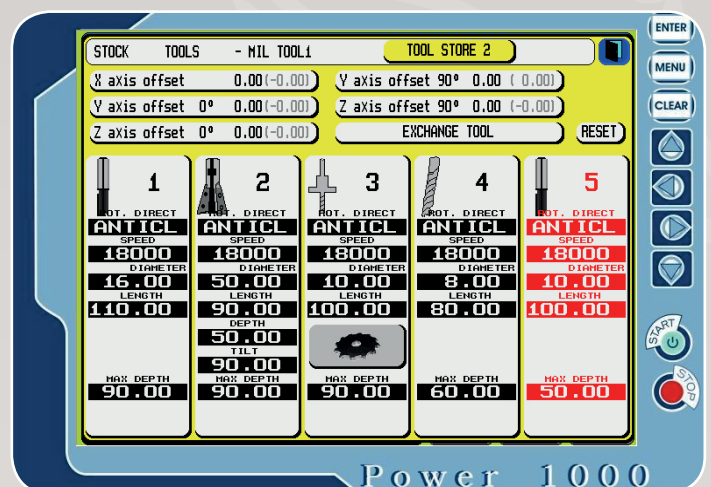
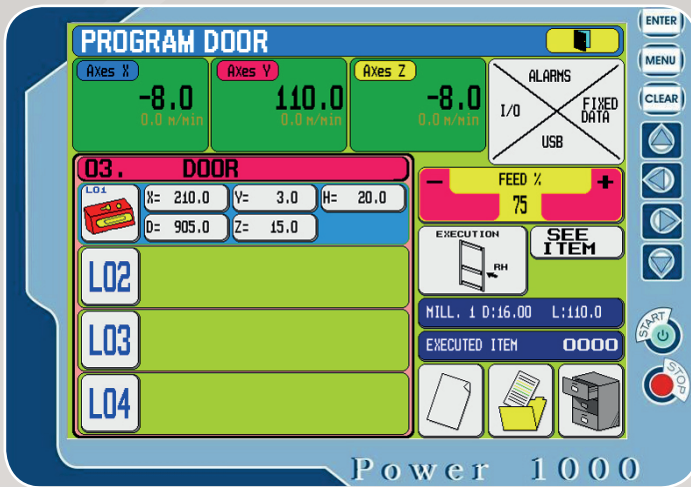

CONTROLLO ELETTRONICO

- Display a colori 15"

- Sistema operativo personalizzato CENTAURO
- Macro pre impostate
- Porta USB
- Porta Ethernet per collegamento in rete

ELECTRONIC CONTROL

- 15" color display

- Customized Operating System CENTAURO
- Preset Macro
- USB port
- Ethernet for network connection

COMMANDE ELECTRONIQUE

- Ecran couleur 15"

- Système opérationnel personnalisé CENTAURO
- Macro préenregistrée
- Port USB
- Port Ethernet pour connexion réseau

CONTROL ELECTRONICO

- Pantalla a color de 15"

- Sistema operativo personalizado CENTAURO
- Plantilla macro
- Tarjeta USB
- Ethernet para la conexión a la red



Electromandrino (kW 3,3; 18000 g/m)
 per eseguire forature e fresature
 su porte e telai sia su piano orizzontale (0°)
 che verticale (90°)

Router motor (kW 3,3; 18000 r/min)
 for drilling and milling
 on doors and frames both
 on a horizontal (0°) and vertical (90°) plane



Electromandrino (kW 3,3; 18000 t/min)
 pour le fraisage et le perçage
 des portes et des cadres sur les deux plans
 horizontal (0°) et vertical (90°)

Electromandrill (kW 3,3; 18000 g/min)
 para fresado y taladrado
 sobre puertas y marcos en los planos
 horizontal (0°) y vertical (90°)

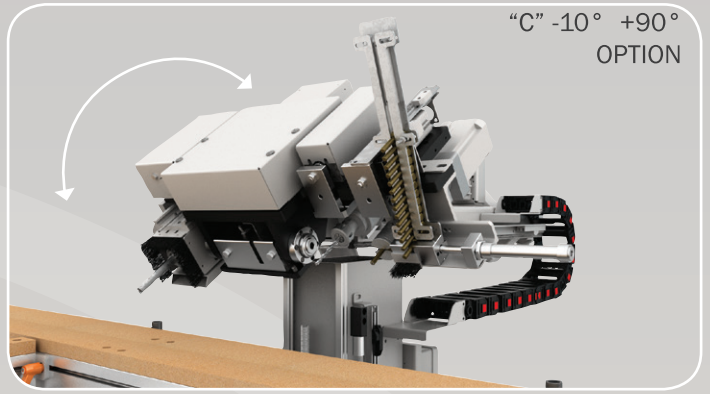
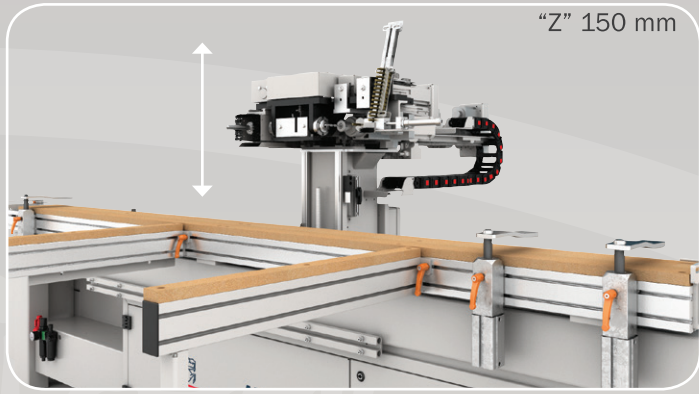

LAVORAZIONI - PROCESSING - USINAGES - PROCESAMIENTO

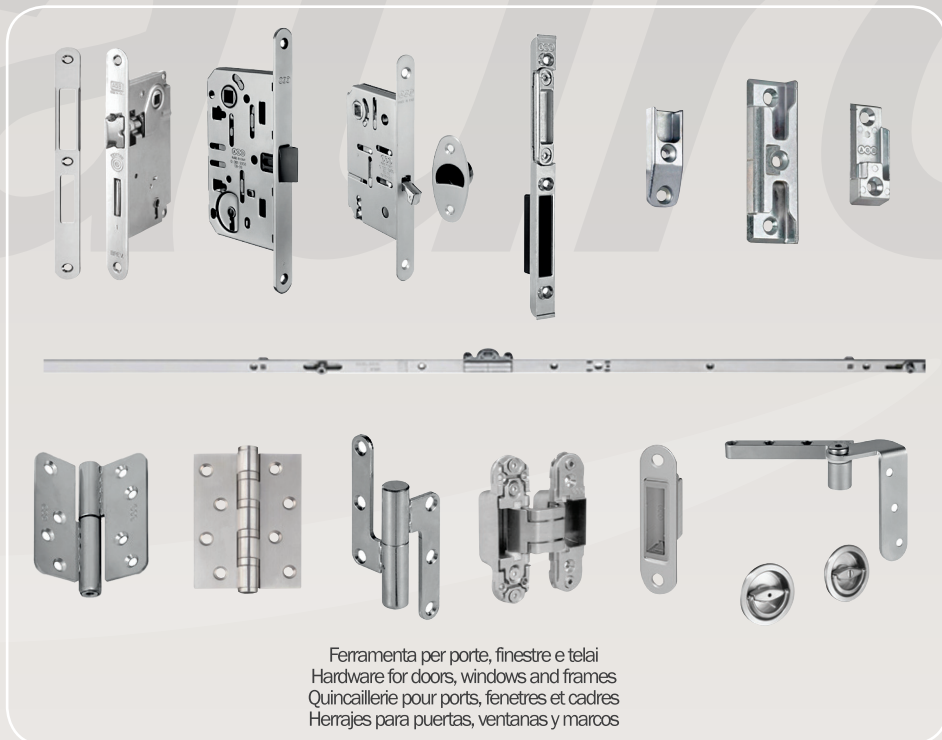
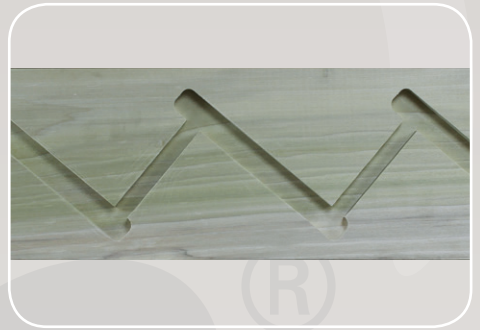
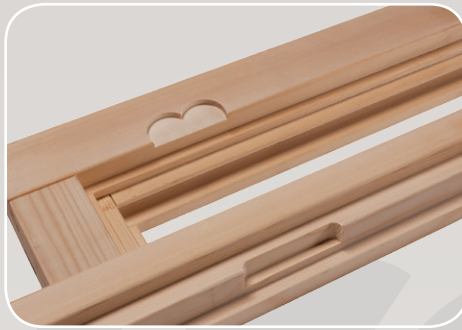

ALFA NC MILLING MACHINE

QUALITÀ E MASSIMA FLESSIBILITÀ NELLE SOLUZIONI PER FRESATURA E ANUBATURA

QUALITY AND MAX FLEXIBILITY IN MILLING AND ANUBA HINGES INSERTING SOLUTIONS

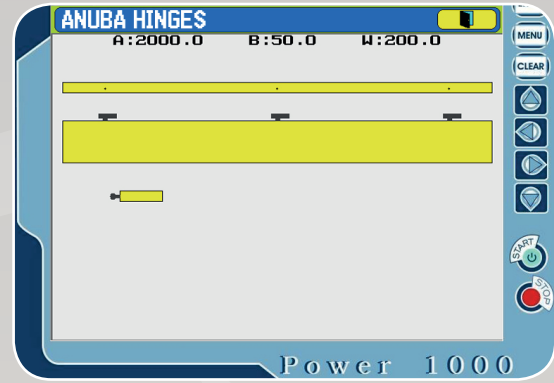

OPTIONS

ANUBATURA AUTOMATICA

Versione multifunzione a 4 assi controllati e interpolati
Completamente programmabile da CN esegue la foratura
e l'inserimento di cerniere anuba su porte e telai.

Il gruppo è composto da un secondo elettromandrino (kW 2,2; 18000 g/min),
unità di avvitatura gestita da motore brushless e caricatore automatico
Inclinazione -10° +90° controllata da CN

AUTOMATIC ANUBA INSERTING DEVICE

Multi-function version, 4-axis controlled and interpolated
Fully programmable by CN executes drilling and insertion
of anuba hinges on doors and frames.

The device is composed of an additional router motor (kW 2,2; 18000 r/min),
inserting unit operated by brushless motor and automatic loader
Tilt -10° +90° controlled by NC

GROUPE DE PERCAGE, VISSAGE ET INSERTION DES FICHES ANUBA

Version multifonction, à 4 axes contrôlée et interpolée

Totalement programmable par CN exécute le forage et l'insertion
de charnières anuba sur les portes et les cadres.

Le groupe est composé d'un électromandrin supplémentaire (kW 2,2; 18000 t/min),
unité d'insertion actionnée par un moteur brushless et un chargeur automatique
Inclinaison -10° +90° contrôlée par CN

GRUPO DE TRABAJO AUTOMATICO PARA ANUBA

Versión multifuncional en 4 ejes controlados y interpolados

Totalmente programable por CN ejecuta el taladrado y la inserción de bisagras anuba
en puertas y marcos.

El grupo está compuesto de un cabezal fresador suplementario
(kW 2,2; 18000 g/min),
unidad de inserción accionada por motor brushless y cargador automático
Inclinación -10° +90° controlada por CN

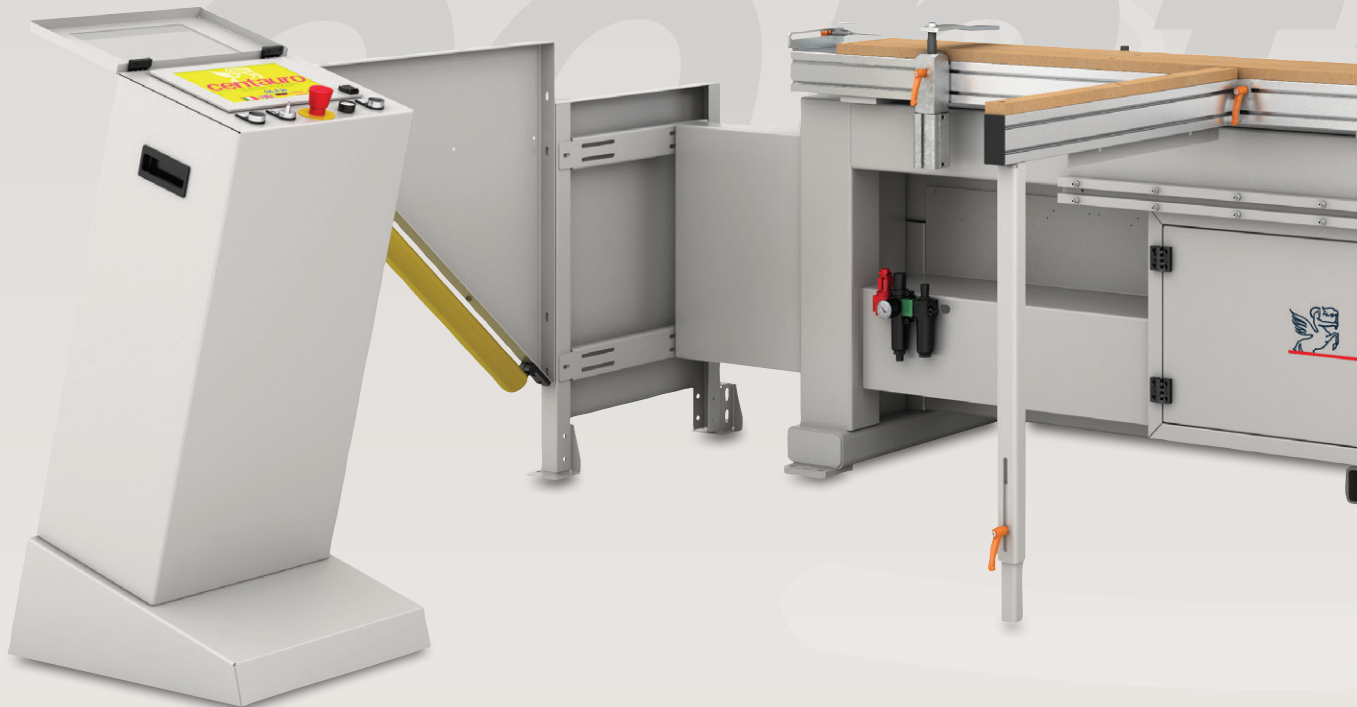
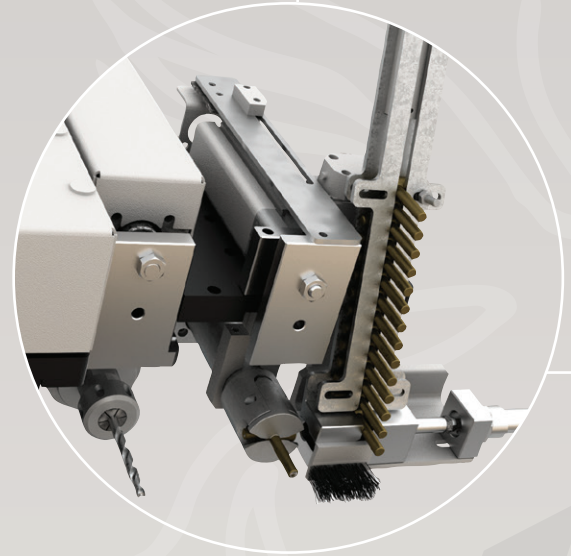



UNITA' FORATRICE PER ANUBA

Unità a forare kW 0,75; 4500 g/min

Completamente programmabile esegue fori per cerniere anuba su porte e telai.

Inclinazione -10° +90° manuale

Avvitatura anuba manuale

DRILLING UNIT FOR ANUBA HINGES

Drilling unit kW 0,75; 4500 r/min

Completely programmable performs holes for anuba hinges on doors and frames.

Tilt -10° + 90° manual

Manual inserting of anuba hinges

UNITE DE PERCAGE

Unité de perçage 0,75 kW; 4500 t/min

Totalment programmables effectue des trous pour charnières anuba sur les portes et les cadres.

Inclinaison -10° + 90° Manual

Insertion manuel des fiches anuba

UNIDAD DE TALADRADO PARA BISAGRAS ANUBA

Unidad de taladrado kW 0,75; 4500 g/min

Completamente programable realiza agujeros para bisagras anuba sobre puertas y marcos.

Inclinación manual -10° + 90°

Atomillado manual de bisagra anuba

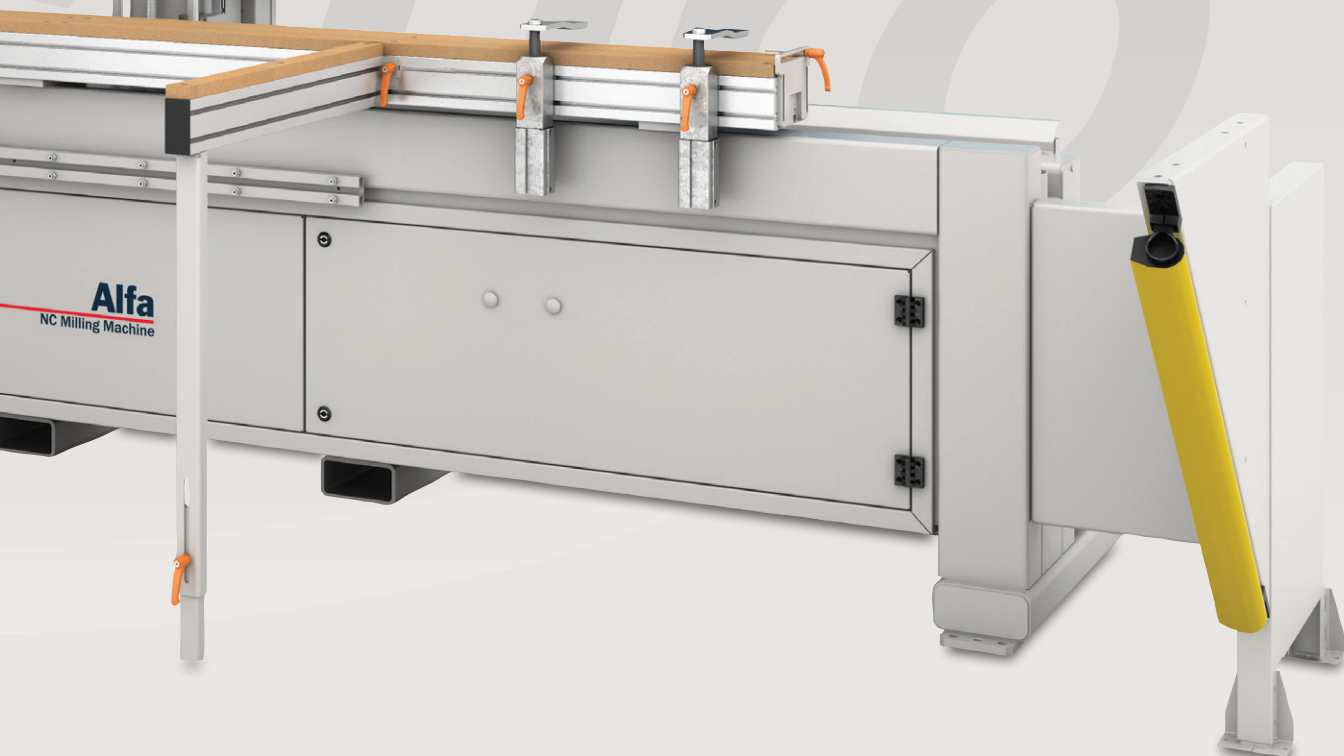
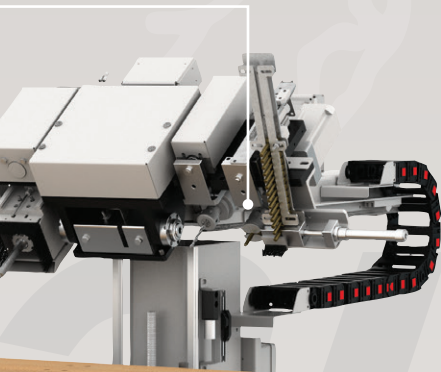
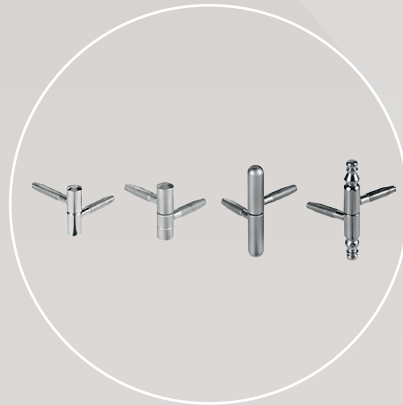

OPTIONS



- Cambio utensili manuale:
- ISO 30 pneumatico, completo di 2 porta utensili
 - HSK40 meccanico, completo di 2 porta utensili

- Manual tools change:
- ISO 30 pneumatic, c/w 2 toolholder
 - HSK40 mechanical, c/w 2 toolholder

- Changement outils manuel:
- ISO 30 pneumatique, avec 2 porte-outils
 - HSK40 mécanique, avec 2 porte-outils

- Cambio herramienta manual:
- ISO 30 neumático, con 2 portaherramientas
 - HSK40 mecánico, con 2 portaherramientas

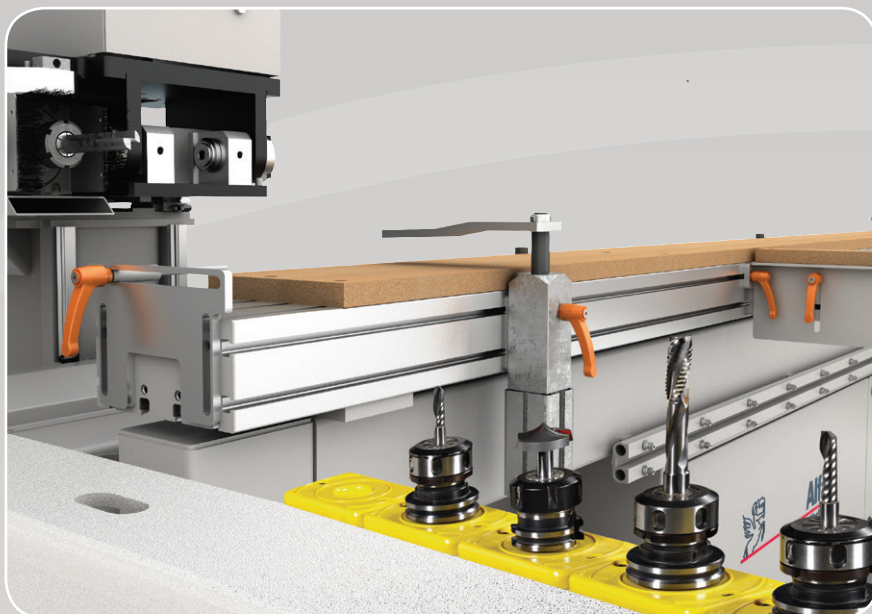

Unità a fresare/forare kW 2,2 (HP 3) con pinza ER25 e fresa diam. 3 mm

Additional milling unit kW 2,2 (HP 3) c/w ER25 collet and cutter diam. 3 mm

Unité de fraisages supplémentaire kW 2,2 (HP 3) avec pince ER25 et fraise diam. 3 mm

Cabezal fresador suplementario kW 2,2 (HP 3) con pinza ER25 para mecha diam. 3 mm

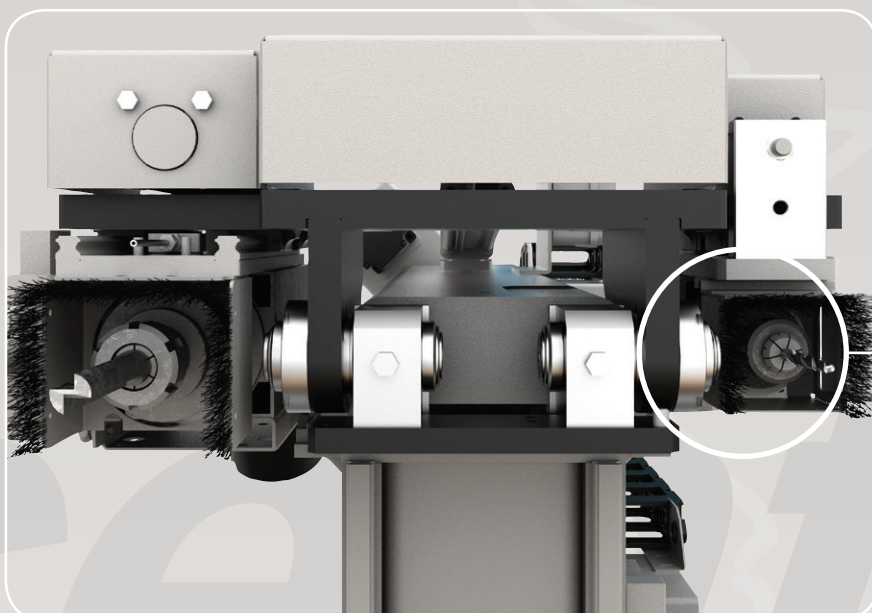

IONS

QUALITE' ET MAX FLEXIBILITE' EN SOLUTIONS POUR FRAISAGE ET FICHES ANUBA

CALIDAD Y GRANDE FLEXIBILIDAD EN LAS SOLUCIONES PARA FRESADO Y TALADRADOS PARA ANUBA

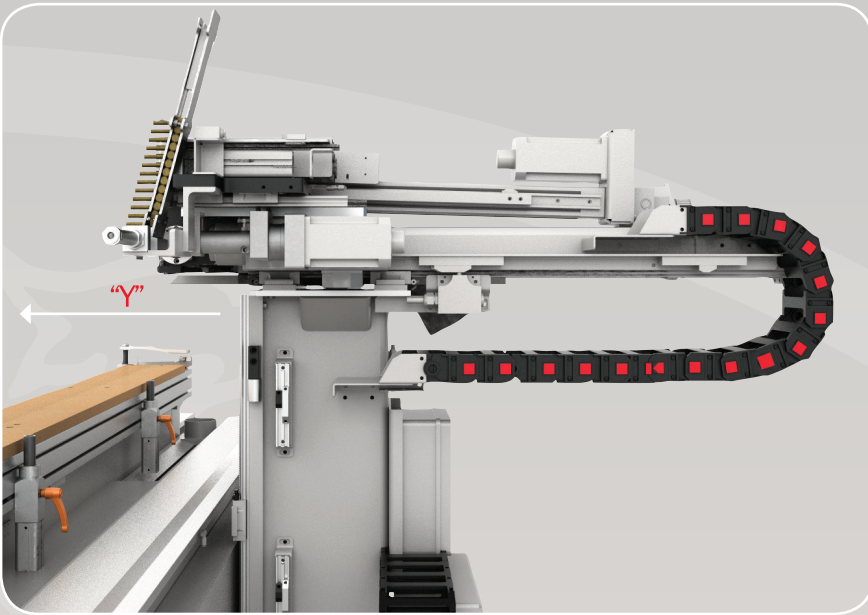

Capacità asse Y fino a 800 mm

Y-Axis capacity up to 800 mm

Capacité axe Y jusqu'à 800 mm

Capacidad eje Y hasta 800 mm

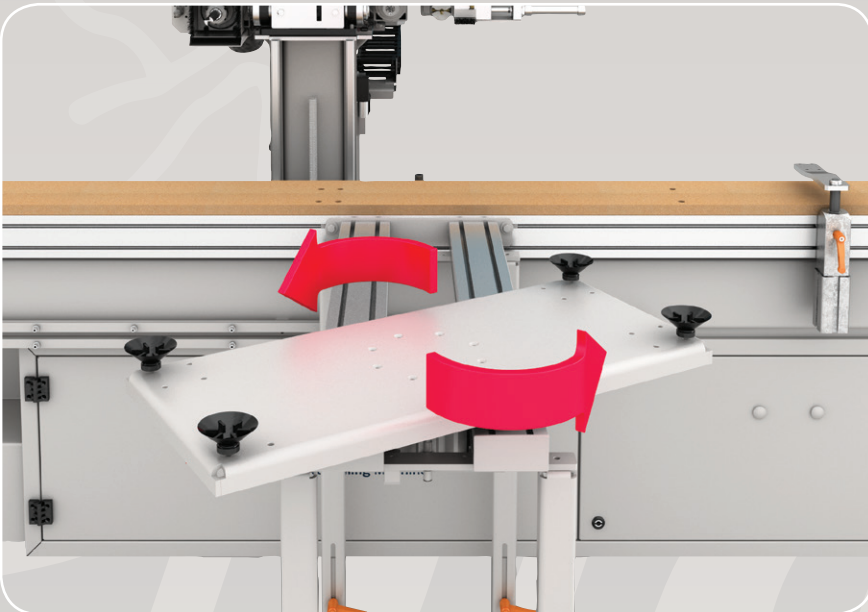

Dispositivo di sollevamento e rotazione porta

Lifting and turning door device

Dispositif de levage et rotation de la porte

Mesa rotante para girar la puerta



012345678900
BAR CODES
READING DEVICE



OPTIONS

QUALITÀ E MASSIMA FLESSIBILITÀ NELLE SOLUZIONI PER FRESATURA E ANUBATURA

QUALITY AND MAX FLEXIBILITY IN MILLING AND ANUBA HINGES INSERTING SOLUTION



Giunzioni a scomparsa tipo "Lamello"

Join wood system type "Lamello"

Assemblage du bois model "Lamello"

Ensamblar tipo "Lamello"

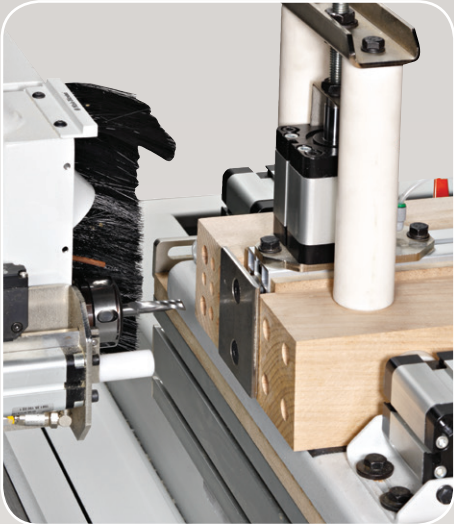

Forature e fresature di testa

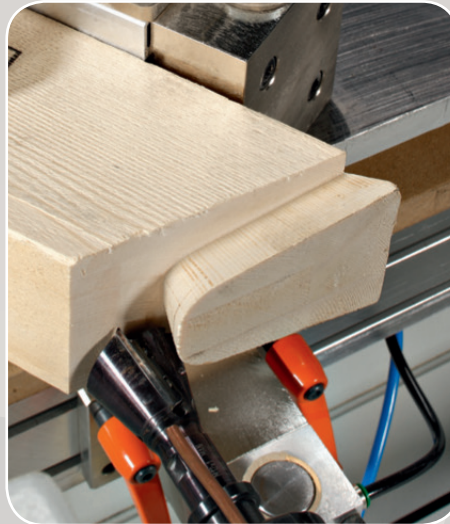

Head drilling/milling machining

Perçage et fraisage à la tête



Perforación y fresado frontal

APPLICAZIONI SPECIALI

SPECIAL APPLICATION

APPLICATIONS SPÉCIALES

APLICACIONES ESPECIALES

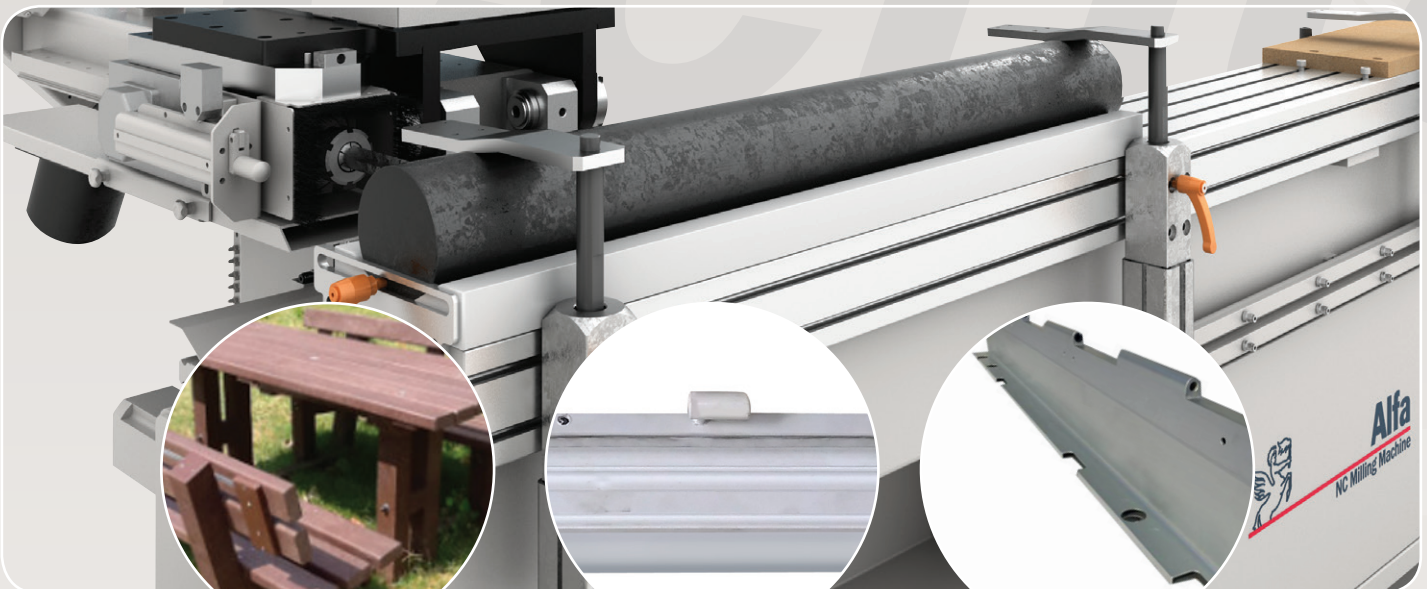

PLASTIC

PVC

ALUMINUM

INCLINAZIONE STANDARD 0°+90°
 TILTING 0°+90° STANDARD
 INCLINAISON STANDARD 0°+90°
 INCLINACIÓN STANDARD 0°+90°

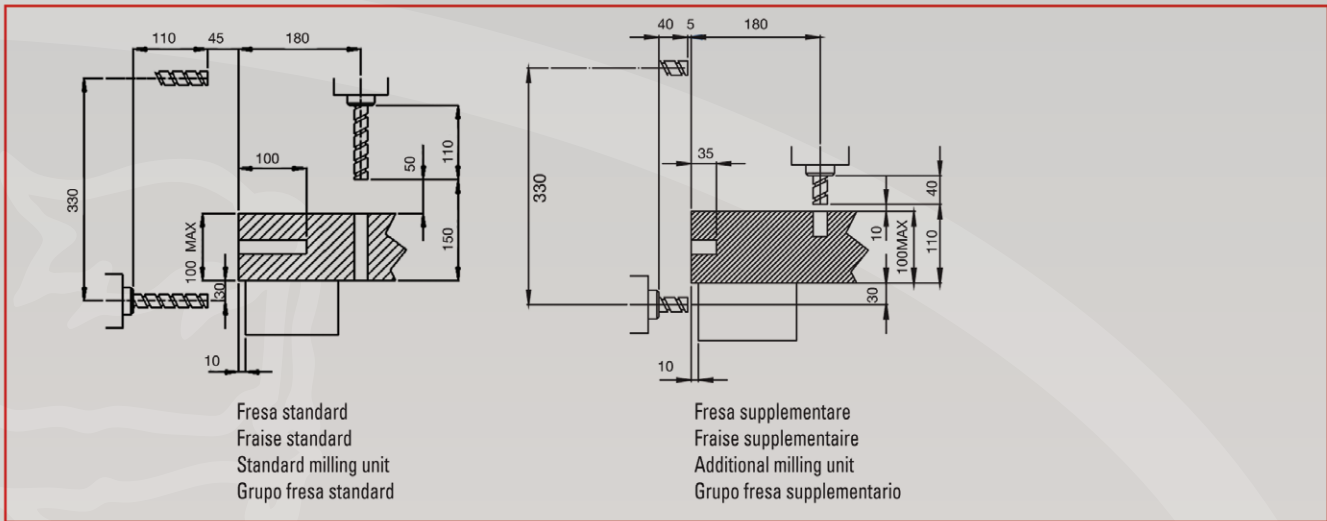

INCLINAZIONE -10°+90° CONTROLLATA
 TILTING -10°+90° CONTROLLED
 INCLINAISON -10°+90° CONTROLLEE
 INCLINACIÓN -10°+90° CONTROLADA

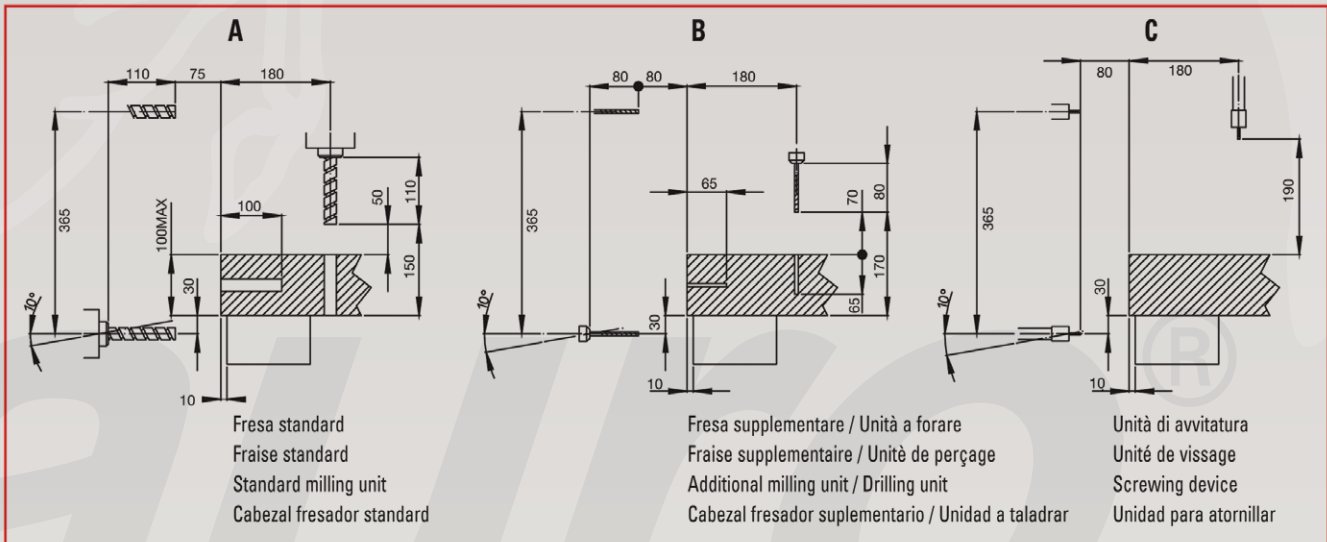

CORSE UTILI ASSE X
 STROKE X AXIS
 CAPACITÉ AXE X
 RECORRIDO EJE X

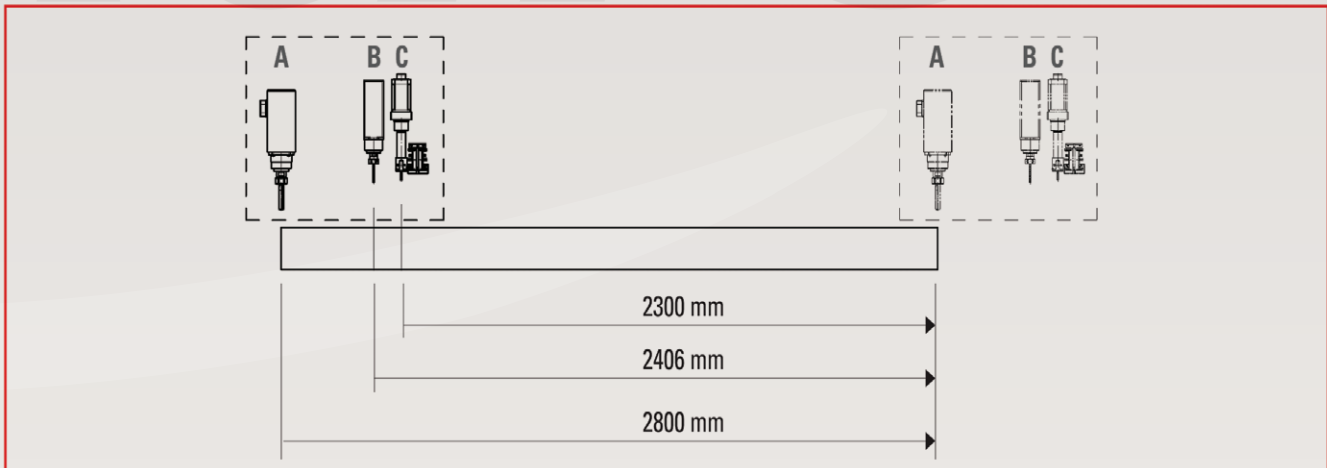

DATI TECNICI / TECHNICAL DATA / DONNÉES TECHNIQUES / DATOS TECNICOS

* opzionale / optional / sur demande / Opcional

FRESATRICE CN PER PORTE, TELAI E PANNELLI IN LEGNO FRAISEUSE CN POUR PORTES, CADRES ET PANNEAUX EN BOIS	NC MILLING MACHINE FOR DOORS, FRAMES AND WOODEN PANELS CENTRO DE MECANIZADO PARA PUERTAS, MARCO Y PANELES DE MADERA	ALFA
Capacità utile assi X-Y-Z (fresa) / Axis output X-Y-Z (milling unit) Capacité axes X-Y-Z (fraise) / Capacidad ejes X-Y-Z (fresa)		2800 180 (400*) 150 mm
Pinza ER32 per fresa ø 16-15 mm / ER32 collet for milling cutter 16-15 mm ø Pince ER32 pour fraise ø 16-15 mm / Ataque ER32 para fresa ø 16-15 mm		nr. 1
Velocità max assi X-Y-Z / X-Y-Z axis speed Vitesse max. axes X-Y-Z / Velocidad maxima ejes X-Y-Z		35/7,5/7,5 mt./mm
Dimensioni max. piano di lavoro / Max. working table dimensions Dimensions max. table de travail / Dimensiones max. mesa de trabajo		2870x180 mm
Battute posteriori rientranti / Retractable rear stops Butées posterieures escamotables / Topes traseros entrantes		nr. 2
Pressori anteriori / Front clamps / Presseurs antérieurs / Prensaes anteriores		nr. 3
Battute laterali (1 sx - 1 dx) / Side stops (1 RH - 1 LH) Butées laterales (1 droite - 1 gauche) / Topes laterales (1 derecho - 1 izquierdo)		nr. 2
Prolunghe frontali di appoggio pezzo / Front table extensions for piece support Rallonges frontales d'appui de la pièce / Prolonga frontal de apoyo puerta		nr. 2 (L. 750 mm)
Potenza elettromandrino fresa / Router motor power / Puissance electro-mandrin de la fraise / Potencia electromandril fresa		3,3 (5,6*) kW
Velocità elettromandrino programmabile / Programmable router motor speed Vitesse electro-mandrin programmable / Velocidad electromandril programable		0 - 18000 g./min
Potenza elettromandrino fresa supplementare / Additional router motor power Puissance electro-mandrin de la fraise supplementaire / Potencia electromandril fresa suplementaria		2,2* kW
Velocità elettromandrino fresa supplementare programmabile / Additional router motor speed Vitesse electro-mandrin de la fraise supplementaire / Velocidad electromandril fresa suplementario		0 - 18000 g./min
Inclinazione fresa / Inclination of router head / Inclinaison de la fraise / Inclinación fresa		0°/90° (-10°+90°*)
Potenza unità a forare / Drilling unit motor power / Puissance unité de perçage / Potencia unidad a taladrar		0,75 kW *
Velocità unità a forare / Drilling unit motor speed / Vitesse unité de perçage / Velocidad unidad a taladrar		4500 g./min *
Inclinazione unità a forare / inclination of drilling unit / Inclinaison du unité de perçage / Inclinación unidad a taladrar		-10°+90°*
Rotazione unità di avvitatura / Rotation of screwing device / Rotation unité de vissage / Rotación unidad para atornillar		0 - 375 g./min *
Programmatore elettronico Power 1000 / Electronic control Power 1000 / Programmateur électronique Power 1000 / Programador electronico Power 1000		Touch Screen 10"
Bocche aspirazione / Dust extraction outlets / Buses d'aspiration / Boca de aspiracion		nr. 1 ø 80 mm / nr. 2 ø 100 mm
Pressione d'esercizio impianto / Operating pressure / Pression de service / Presion de servicio		6 (Lit./min. 300) bar
Peso netto / Net weight / Poids net / Peso neto		1300 kg

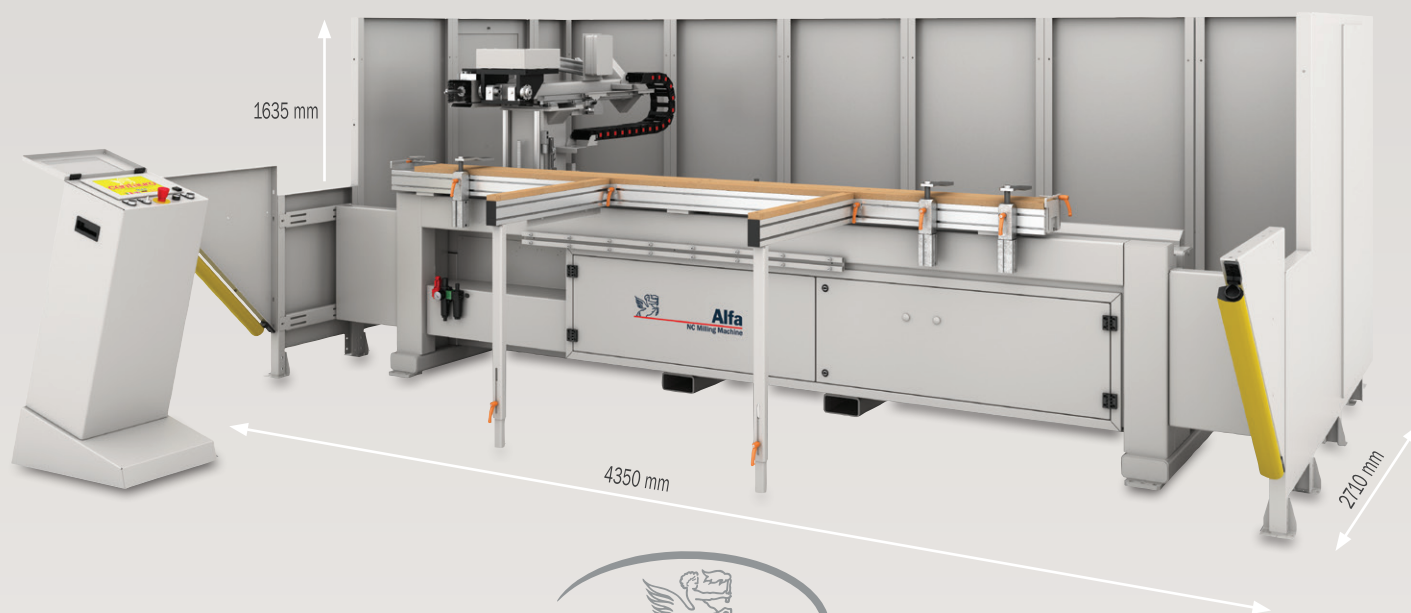

Centauro S.p.A.

41010 Limidi (Modena) Italy

Via Carpi Ravarino, 87 - Tel. 059 855411 - Fax 059 561109

centauro@centaurospa.it - www.centaurospa.it